



BADU[®]

Super 90 Series



Flow Rates from 230 - 500 lpm

Quieter, smoother performance

German design & engineering

Available in 1.0 to 2.0 HP

Easy to remove non-corrosive lid with handle

Robust construction, highest quality material



BADU[®]

Super 90 Series

The Speck SUPER 90 Series is the ideal choice for all domestic pool and spa applications including heating, salt chlorination and automatic pool cleaning.

Features:

- A high resistance to corrosion and salt water
- Maximum effectiveness at low power input
- The ultimate in reliability
- No contact between motor and pump shaft with water
- Highest quality mechanical seal
- Fan cooled - suitable for high ambient temperatures
- Closed impeller
- Stainless steel motor shaft
- Easy to remove clear strainer lid
- Every pump factory wet tested for quality control

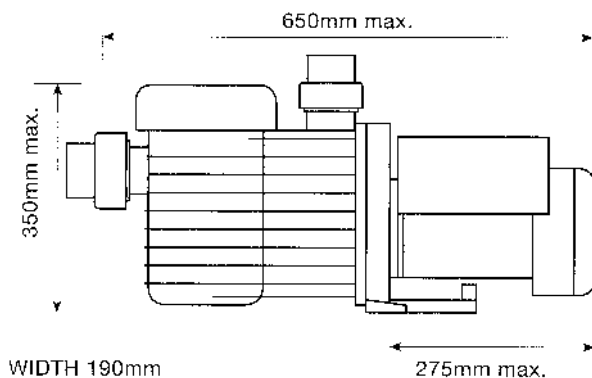
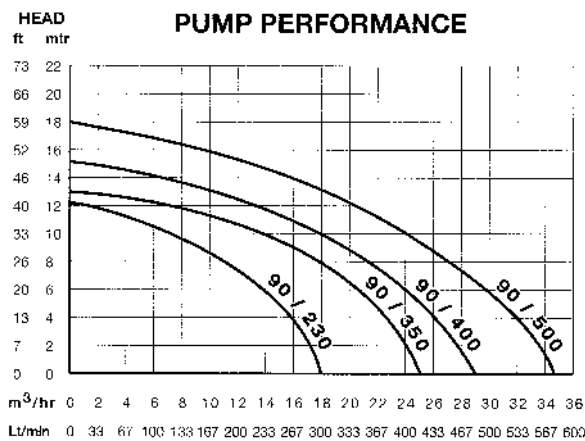

	90/230	90/350	90/400	90/500
Head Max/Min - m	12/4	13/4	15/4	18/4
Inlet Connection - mm	50	50	50	50
Outlet Connection - mm	40	40	40	40
Motor Speed - RPM	2850	2850	2850	2850
Power Input - V	240	240	240	240
Power Output - watts	650	750	930	1100
AMPS	4.2	4.7	6.0	6.6
Weight - kg	11	13	15	19
Max Water Temp - Deg.C	40	40	40	40